



# Investigating the Factors Affecting the Use of Financial Information in Managerial Decision-making in Governmental Organizations

Mortaza Ghabdian<sup>1\*</sup>, Yosef Ramezani<sup>2</sup>

<sup>1</sup>Department of Management, Financial Management, Neyshabur Branch, Islamic Azad University, Neyshabur, Iran, <sup>2</sup>Department of Management, Human Resources, Neyshabur Branch, Neyshabur, Iran. \*Email: [ghabdianmorteza@gmail.com](mailto:ghabdianmorteza@gmail.com)

## ABSTRACT

This study aims to investigate the factors affecting the usefulness of financial information in intra-organizational decision-making. The statistical population comprises all the auditors of the supreme audit court and the selected sample includes 118 auditors. This research is a descriptive-survey study and for data collection, questionnaire was used. The research findings with a structural equation modeling approach demonstrated that there is a significant positive relationship between the external and internal factors of the organization and usefulness of financial information in managerial decision-making. Also, findings revealed that of the organization's external factors, the role of the media and public networks has the greatest impact on the usefulness of financial information in intra-organizational decision-making and out of the organization's internal factors, the existence of sufficient computational tools has the greatest effect on the usefulness of financial information in intra-organizational decision-making. Besides, individual factors compared to organizational factors have more influence on the usefulness of financial information.

**Keywords:** Usefulness of Financial Information, Extra-organizational Factors, Intra-organizational Factors, Managerial Decision-making, Supreme Audit Court

**JEL Classifications:** G2, G41, L2

## 1. INTRODUCTION

From long ago, the process of decision-making in all the organizations of the public and private sectors has generally followed the same approach. Nevertheless, the usefulness of decision-making models depends on the circumstances surrounding the organizations (Tarter and Hoy, 1998). Information is considered to be useful when it enjoys the features of timeliness, relevance and reliability and only the system that creates the necessary coordination between the information needs of internal users and hardware and software processing capacity of the organization has the ability to provide this information (Mack, 2004). On the other hand, change in the environmental and external conditions of the organization and information needs of extra-organizational users is an important issue which affects the coordination between information system and its reports with managerial decisions.

Belkaoui (1985) states that accounting is not developed in vacuum but reflects a special environment which is developing and when the environment changes, the demand for change in the financial information presented by the accounting system leads to the development of this system. For this reason, a large number of international studies have been allocated to the investigation of governmental accounting and its environment.

Organizational changes in management and accounting of the public sector are potentially influenced by a set of internal and external factors of decision-making about preparation and dissemination of useful information for decisions (Haldma and Lääts, 2002). Usefulness of the information disclosed in financial reports for the purposes of decision-making is dependent on various factors related to companies. Cohen et al. (2007), Grossi and Reichard (2009), Mack and Ryan (2006) and Mack (2004) believe that the rate of using financial information for decision-making is a function of its usefulness in line with the objectives of

decision-making. Further, Grossi and Reichard (2009) believe that the use of financial information depends on different organizational factors such as the lack of specialized knowledge and accounting training and reporting systems.

In Iran, with regard to the growing economic, political and social environment, particularly a change in the budgeting system from a program to an operational basis, the need for useful accounting information for decision-making and accountability on the part of public managers has increased. Thus, it seems that state accounting system in Iran like most of the countries in the world is on the verge of structural reforms. But the method of reforms and manner of the interaction between the factors influencing this process are a serious challenge and the necessity of developing a theoretical framework which can explain the reform process and describe its surrounding atmosphere and also be used for prediction is undeniable.

The present study provides a clear picture of the reforms facing the authorities and policy-makers in government accounting system by showing the possible routes of reforms and predicting the environmental and intra-organizational factors affecting the usefulness of financial reporting system in the decision-making process of managers. Also, this research addresses the question as to which variables have a significant impact on the decision-making process using accounting information in Iran.

## 2. RESEARCH LITERATURE REVIEW

### 2.1. Theories Associated with Accounting Reforms of the Public Sector

In the research literature, to solve the problems related to managerial decision-making by reliance on the accounting information of the public sector, institutional and contingency theories have been raised. These theories deal with the fact that for doing things, there is not only one way as a superior method, but the method of managing the organization depends on the leadership style which is itself dependent upon a series of external and internal limiting variables.

Limiting variables may include the organization size, the manner of adaptation to the surrounding environment, difference in resources and the amount of the organization's reliance on technology.

#### 2.1.1. Contingency theory

Contingency theory is one of the theoretical perspectives in the field of organizational behavior, which emphasizes contingency methods or restrictions such as size, environmental uncertainty, technology and environmental pressures affecting the functioning and development of organizations (Chenhall, 2003; Thomas, 1991). This theory attempts to identify the relationships between internal and external features of organizations and management capacity (Ryan et al., 2002). According to this framework, requirements and restrictions affect the organizational structure in the form of education, privatization, diversification and bureaucracy.

To explain how environment influences the accounting system, contingency theory can be used which simply argues that the

effective management structure is dependent on the conditions. Hence, difference in the environment where the organization operates can lead to different decisions as the optimal method of financial reporting and disclosure level. Belkoui (1985) is one of the individuals who have investigated the impact of environmental factors on accounting based on the contingency approach. He states that the search for finding the relationship between accounting development indicators and economic, political and social development indicators requires the presentation of a contingency theory for international accounting. In the field of government accounting, Professor Klaus Loader and his team were among the first and best-known academics who in the late 80s noticed the importance of knowing the cause of changes in government accounting and conducted a study that led to the development of a theoretical framework to carry out international comparative studies of government accounting with the title of the contingency model of innovations in government accounting. However, numerous criticisms have been made against this model so that these criticisms caused that several modified models from the original model to the final model entitled the contingency model of financial management reforms be provided by professor Loader in 2001. But despite all reforms, this model is not still able to explain the whyness of the government accounting systems (content of the system) but has partly managed to explain the cause of reforms (Lüder, 2002). However, in Grossi and Reichard (2009) opinion, this model has played the role of a paradigm for research in this area despite its deficiencies such that many writers have applied this model for describing contextual conditions or reforms of the public sector in countries which almost include the countries around the world.

#### 2.1.2. Institutional theory

In the literature of institutional theory, expectations and values are regarded as intra-organizational and extra-organizational factors and rules of society have a significant role in decisions to change the accounting system. This theory supports the assumption that organizations gain legitimacy in case of meeting the extra-organizational expectations such as pressure to introduce specific accounting procedure regardless of its benefits. Institutional theory is used to describe the reaction of organizations to the pressures of institutional environments (Carpenter and Feroz, 2001; Carpenter et al., 2007; Chapman et al., 2009).

In connection with changes in reporting and accounting systems and information usefulness, the studies have been generally oriented to the investigation of the effect of legal and organizational pressures, lack of information on new data prepared according to the accrual basis, lack of human resources and the resistance to change. In the meantime, some factors are directly associated with the individual characteristics of decision-makers and others as a result of standards and certain organizational conditions. The factors related to the individual characteristics of decision-makers such as skills, knowledge and experience about concepts and tools of financial management seem to be especially relevant in determining the rate of the usefulness of financial information (Askim, 2008; Paulsson, 2006; Yamamoto, 2008). The amount of using the data of financial reports depends on the usefulness in data decision which is dependent on the potential benefits of

data for users (relevance, meeting the expectations and so on). But there is one question about the Understandable financial information. Grossi and Reichard (2009) stated that the demand for a set of financial reporting data depends on various individual and organizational factors such as knowledge or culture, universality, use of financial information and the mediating role of suppliers and demand ants of effective factors.

## 2.2. Research Background

Taliban et al. (2011) conducted a study and provided a theoretical framework to explain and predict the accounting reforms of the Iranian government based on Lüder (2002) international contingency model. Findings of this survey study indicate that Iran's state accounting on the verge of fundamental transformation and the main driver of this change is the increased demand for more information following the reforms raised in public sector management in Iran, including the legal requirements about the operational budget. The provided model has been also used in predicting the future trend of reforms in Iran, which approves the predictive power of Lüder (2002) model.

Vakili-Fard and Nazari (2012) examined the factors affecting the implementation of Accrual accounting system. The factors studied in this research consist of management, human resources, rules and regulations, theoretical framework and a culture of accountability and seeking answer. Considering the survey nature of this study, the data required for testing the research hypothesis has been collected through distributing the researcher-made questionnaires among a sample of financial managers, heads of accounting and professional accountants. The research results revealed that the factors of management, expert human resources, rules and regulations, theoretical framework and a culture of accountability and seeking answer are effective in the application of accrual accounting in the public sector and in the meanwhile, the factors of management and theoretical framework have respectively the highest and lowest impact.

Almshah (2014) performed a study to investigate the factors affecting the adoption of environmental management accounting methods. Environmental management accounting as an intra-organizational branch of environmental accounting is a powerful system which helps the management for the optimal control of the consumption of raw materials, water, energy flows and fuel, creation and disposal of wastes and prevention of environmental pollution. The results suggest that low priority of environmental accounting, resistance to changing the traditional methods, efficiency or considerations of costs and benefits, limited resources and skilled manpower and difficulty of collecting and summarizing the environmental costs in relation to the adoption or non-adoption of EMA methods.

Safdari et al. (2015) evaluated the role of organizational factors in the implementation of operational budgeting. To this end, this study has been carried out with the aim of examining the role of organizational factors in the implementation of operational budgeting in lien with upstream rules. Change in the operational budgeting practice in governmental bodies has been accompanied by intra-organizational and extra-organizational challenges. In this

study, from among the extra-organizational factors, environmental factors and the government size have been recognized as the most important factors and intra-organizational factors including the compatibility between equipment, human resources and financial resources can be mentioned as the most important challenges in non-realization of operational budgeting. Ultimately, operational budgeting is realized through the attention to culture and leadership, commitment and support of implementation, the target group conditions, the actual cost, development of measurement indicators and attention to the executives' orientation and organizational climate.

Presence et al. (2015) investigated the factors influencing the incidence of deficiency in the financial control systems of executive agencies. In this study, while explaining and analyzing the Current national control system governing the governmental bodies, three categories of causes of deficiencies in financial control systems have been examined, which include Human factors, Government accounting system used and legal deficiencies. The first two categories have an internal aspect and the third factor is related to the current financial and computational rules. The obtained results demonstrated that the above factors are all effective in the creation of deficiency in the internal control system.

Tudor and Mutiu (2005) assessed the process of change from the cash accounting basis to the accrual basis. The achieved results indicated that the implementation of Accrual accounting involves the development of information and communication technology and improvement of executive methods and in order to ensure that accounting information is presented fully, correctly and on time, a legal framework should be also established. Additionally, the implementation of Accrual accounting needs the training of the current employees and employment of new staff.

Nogueira and Jorge (2016) evaluated the factors explaining the use of financial reports in the decision-making of the government in Portugal. This study aimed to identify the external and internal factors in the internal decision-making of governmental organizations. The findings showed that the pressure of professional organizations and national problems and issues (external factors) and also lack of knowledge and proper training in the field of information systems (intra-organizational factors) are the factors that have the greatest effect on the usefulness of financial reports for decision-making.

## 3. RESEARCH HYPOTHESES

### 3.1. Hypothesis 1

Extra-organizational factors including political and governmental pressures, pressure of professional and regulatory organizations, media and public networks and citizens have a significant impact on the usefulness of financial reporting in the internal decision-making of governmental organizations.

### 3.2. Hypothesis 2

Intra-organizational factors including the lack of knowledge and information system training, lack of professional experience, complexity of information based on the accrual basis of

accounting, resistance to change, non-compliance of accounting information systems with the company's mission and goals, excessive workload and insufficient computational tools make a significant effect on the usefulness of financial reporting in the internal decisions of governmental organizations.

## 4. MATERIALS AND METHODS

### 4.1. Research Method

This research is a descriptive survey and in terms of purpose, it is an applied study. In this study, the expanded form of the questionnaire of Nogueira and Jorge (2016) has been used for data collection. Therefore, the questionnaire research technique has been recommended as the most appropriate method in this study. To document the results of statistical analysis, Structural equation modeling has been used with the aid of Eviews software to analyze the hypotheses.

### 4.2. Statistical Population and Sample Selection

Out of the target population in this study which included auditors and managers of the supreme audit court in Razavi Khorasan Province and amounted to 170 individuals, 118 subjects from the auditors were chosen as the final sample using Morgan table.

### 4.3. Reliability of the Assessment Tool

One of the important conditions for the test to be a reliable tool for predicting and assessing the intended variable is its reliability and stability; that is, by performing the test, similar results should be always achieved. To obtain the reliability coefficient, there are various methods the most important of which are test replication, equating, split-half method, Kuder-Richardson method and Cronbach's alpha (Momeni and Ghiyomi, 2010).

In the present study, Cronbach's alpha method has been employed to measure the questionnaire reliability.

Cronbach's alpha as follows:

$$r_a = \frac{N}{N-1} \left( 1 - \frac{\sum S_i^2}{S_a^2} \right) \quad (1)$$

$r_a$ : Questionnaire reliability coefficient

$N$ : Number of questions

$S_i^2$ : Variance of the answers to the  $i^{\text{th}}$  question

$S_a^2$ : Variance of the entire questionnaire responses

In this study, 30 questionnaires are distributed to assess the reliability rate using the opinions of the supervisor and advisor. Then, Eviews software is applied to determine the reliability and if Cronbach's alpha coefficient for the questions related to each variable is higher than 0.7, it can be concluded that the reliability associated with these questions is confirmed. Cronbach's alpha for each of the research variables has been provided in Table 1.

In this study, to evaluate the questionnaire validity, initially the logic method and then the content directory have been used. In this state, quality and quantity of questions were examined by

the experts and in order to provide the ground for measuring and assessing the validity, the existing standard questionnaires were used whose validity has been confirmed in previous studies. To investigate the validity, the initial research questionnaire was designed and observed by the supervisor and advisor. After taking corrective measures, 30 questionnaires were distributed among the research statistical population and the respondents' comments about the designed questions were obtained.

## 5. RESEARCH VARIABLES

### 5.1. Dependent Variable: Usefulness of Financial Information

According to the theoretical concepts of financial reporting in the public sector, usefulness of financial information is a degree of qualitative characteristics associated with information content (relevance and reliability) which facilitates the use of financial reports for the users in achieving financial reporting including accountability and decision-making.

### 5.2. Independent Variables

1. Extra-organizational factors: Environmental factors including the pressure of government issues (like budget constraints of the company), pressure from regulatory bodies (such as inspection organization, supreme audit court and financial institutions), political pressures from the government, pressure from professional organizations such as the audit organization, media, stock exchange organization and so on.
2. Intra-organizational factors: These factors are under the control of management and include the mismatch between accounting information systems and mission and goals of the company, lack of knowledge and proper training in the field of the company's information system, absence of sufficient computational tools for using the company's information, complexity of financial information based on accrual accounting system, lack of professional experience, resistance to change and so on.

### 5.3. Hypothesis Testing Model

According to the study by Nogueira and Jorge (2016), the following model has been applied in the form of structural equation modeling to analyze the relationship between variables.

$$\begin{aligned} \text{USEFULLNES} = & \beta_0 + (\beta_1 \text{PoliticP} + \beta_2 \text{NatProbP} + \beta_3 \text{ProfOrg} \\ & + \beta_4 \text{ContBodP} + \beta_5 \text{ScPo} + \beta_6 \text{CitControl}) - (\beta_7 \text{LKno} \\ & \text{owTr} + \beta_8 \text{LProfExp} + \beta_9 \text{CpmpplFinlnf} + \beta_{10} \text{Resist} \\ & \text{anc} + \beta_{11} \text{LArt} + \beta_{12} \text{EWorkload} \\ & + \beta_{13} \text{InexMeans}) + \varepsilon_i \quad (2) \end{aligned}$$

In this model, usefulness is the dependent variable and indicates the usefulness of financial information. The independent variable of extra-organizational factors includes the following: PoliticP is the exercise of political pressure; NatProbP is the exercise of pressure by the government (like budget); ProfOrg is the pressure from professional organizations (such as audit organization); ContBodP is the pressure from regulatory bodies (like supreme audit court and inspection organization of the country); ScP is the pressure from media and public networks and CitControl is



the control exercised by citizens. Besides, in this model, internal factors of the organization include the following: LKnowTr is the lack of knowledge and proper training in the field of the company’s information systems; LProfExp is the lack of professional experience; CmplFinInf is the complexity of information based on the accrual basis of accounting; Resistanc is the resistance to change; LArt is the mismatch between accounting information systems and mission and goals of the company; Workload refers to the excessive workload and InexMeans is the absence of sufficient computational tools for using the company’s information.

## 6. RESEARCH FINDINGS

### 6.1. Descriptive Study of the Research Variables

In the Table 2, descriptive statistics corresponding to the research variables have been provided based on the stated scoring. Findings of the following table show that 118 subjects have participated in this study who has completely answered the questionnaire and indeed, there is no missing observation in the research variables.

The range of changes obtained from the difference between the two above indexes suggests that the dispersion of the components of internal factors is greater than the external factors. However, given that the range of changes is severely affected by remote observations, standard deviation is a more appropriate index to

determine the distribution of observations. Mean as the most basic central criterion of observations shows that weighted average for the factor of professional and theoretical organizations is greater than other factors related to the usefulness of the information under study.

In drawing the above chart (Figure 1), the number of questions associated with each research variable has been considered. With respect to the above chart, it is determined that the auditors of the supreme audit court have mostly responded to the options of “agree” and “totally agree” with the scores of 6 and 7. Standard deviation as the most appropriate dispersion index of observations in the above table indicates that in the factor of the lack of professional experience, they have had more different responses and dispersion of observations in the mentioned variable is greater than other variables under investigation.

### 6.2. Data Analysis

#### 6.2.1. Fit of the model

The following structural equation modeling is obtained from fit of the research data in Eviews software, which is analyzed in this section based on the model below.

According to the findings related to the fit of the above model in Figure 2, Chi-square value is equal to 50.81 and the

**Table 1: Cronbach’s alpha coefficients for each of the research variables**

Variables	Question number	Cronbach’s alpha
Political and governmental structure	1–8	0.723
Professional and institutional organizations	9–14	0.712
Media and public networks	15	0.831
Citizens	16	0.842
Lack of knowledge and proper training	17–19	0.921
Lack of professional experience	20	0.711
Information complexity	21	0.783
Resistance to change	22	0.920
Mismatch between accounting information systems and excessive workload	23–25	0.702
Absence of sufficient computational tools	26	0.814
Total questions	26	

**Table 2: Minimum value, maximum value, mean and standard deviation of the research variables**

Variables	Number	Minimum value	Maximum value	Mean±SD
<b>External factors</b>				
Political and governmental structure	118	1.67	7.00	5.5011±0.86395
Professional and regulatory organizations	118	4.00	7.00	5.8453±0.68126
Media and public networks	118	2.00	7.00	5.5085±1.09970
Citizens	118	2.00	7.00	5.5678±1.18739
<b>Internal factors</b>				
Lack of knowledge and proper training in the field of information systems	118	1.00	6.33	3.9880±1.49446
Lack of professional experience	118	1.00	7.00	4.1695±1.62410
Complexity of information based on the accrual basis of accounting	118	1.00	7.00	4.3898±1.50801
Resistance to change	118	1.00	7.00	4.6186±1.26707
Mismatch between accounting information systems and excessive workload	118	1.67	6.67	4.5819±1.17643
Absence of sufficient computational tools for using information	118	1.00	7.00	4.5254±1.46592

SD: Standard deviation

**Figure 1:** A bar graph for the research variables

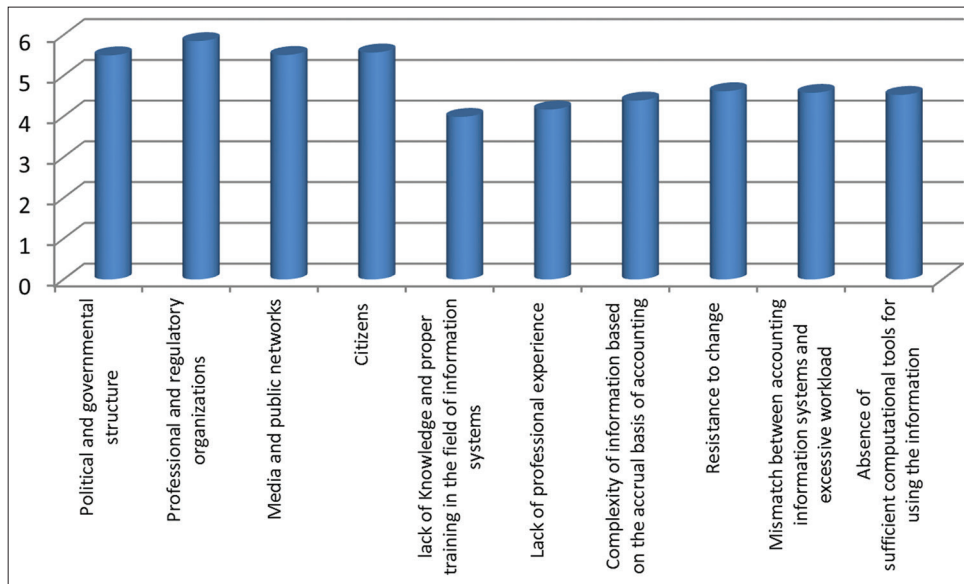

**Figure 2:** Factor analysis model corresponding to the research conceptual model (standardized coefficients)

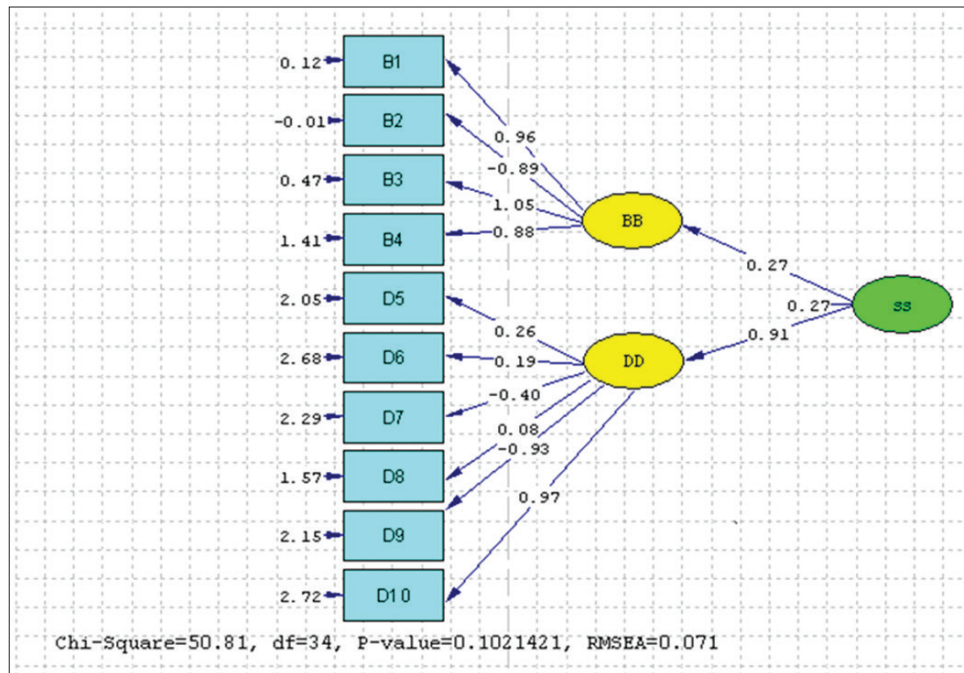

significance level is 0.102. With regard to the statistic value of RMSEA =0.071 which is lower than 0.08, the fitted model is approved. A summary of the model results has been presented in the Table 3.

Finally, indicators related to fit of the final model in the Table 4 suggest goodness of fit the model.

According to the research theoretical foundations, if the ratio of Chi-square to degree of freedom is lower than 3, fit of the model is confirmed. Findings of the above table indicate that the mentioned ratio is 1.49 which is <3. Hence, it can be said with 95% confidence that the fitted model is reliable.

**6.2.2. Investigation of the research hypotheses**

In this section, the research hypotheses are evaluated with regard to the obtained factor loadings. In fact, foundations of analyzing the hypotheses of factor loadings and significance level proportionate to the test statistic correspond to each of the variables (factors).

**6.2.2.1. Testing the first hypothesis**

Organizational factors (outside the control of management) have a significant impact on the usefulness of financial reporting in the internal decision-making of governmental organizations.

Organizational factors in this study have been considered to be political and governmental structure, professional and regulatory

**Table 3: Values of direct effects in the initial research model**

Relationships between variables	Symbol	Factor loading	Standard factor loading	Standard error	T value	Significance level
Political and governmental structure with external factors	B1	0.79	0.96	0.06	13.23	P<0.05
Professional and regulatory organizations with external factors	B2	0.71	0.89	0.048	14.84	P<0.05
Media and public networks with external factors	B3	0.85	1.05	0.086	9.87	P<0.05
Citizens with external factors	B4	0.96	0.88	0.091	10.60	P<0.05
Lack of knowledge and proper training in the field of information systems with internal factors	D5	1.21	0.26	0.10	11.59	P<0.05
Lack of professional experience with internal factors	D6	1.51	0.19	0.11	13.23	P<0.05
Complexity of information based on the accrual basis of accounting with internal factors	D7	1.40	-0.40	0.11	13.33	P<0.05
Resistance to change with internal factors	D8	1.11	0.08	0.092	11.99	P<0.05
Mismatch between accounting information systems and excessive workload with internal factors	D9	1.26	-0.93	0.088	14.36	P<0.05
Absence of sufficient computational tools for using information with internal factors	D10	1.33	0.97	0.10	12.77	P<0.05
External factors with information usefulness	BB	0.33	0.27	0.121	2.727	P<0.05
Internal factors with information usefulness	DD	1.12	0.91	0.231	4.848	P<0.05

**Table 4: Indicators related to fit of the research model**

Fit indicator	Fit value	Satisfactory value	Result
Ratio of Chi-square to degree of freedom	1.49	<3	Model approved
NFI	0.99	Close to 0.9 or more	Model approved
GFI	0.99	>0.9	Model approved
AGFI	0.97	>0.9	Model approved
IFI	1	>0.9	Model approved

organizations, media and public networks and citizens and factor loadings corresponding to each of them have been provided in the Table 5.

Findings of the above table demonstrate that:

- Factor loading of political and governmental structure is equal to 0.79 and its corresponding test statistic is 13.23. Thus, its associated significance level is <0.05 (P < 0.05). Therefore, it can be stated with 95% confidence that the effect of the mentioned factor on the usefulness of financial reporting is significant.
- Factor loading of professional and regulatory organizations is equal to 0.71 and its corresponding test statistic is 14.84. So, its associated significance level is lower than 0.05 (P < 0.05). Thus, it can be said with 95% confidence that the impact of the mentioned factor on the usefulness of financial reporting is significant.
- Factor loading of media and public networks is equal to 0.96 and its corresponding test statistic is 9.87. Hence, its associated significance level is <0.05 (P < 0.05). Therefore, it can be stated with 95% confidence that the effect of the mentioned factor on the usefulness of financial reporting is significant.
- Factor loading of citizens is equal to 0.85 and its corresponding test statistic is 10.60. Therefore, its associated significance

level is lower than 0.05 (P < 0.05). Thus, it can be said with 95% confidence that the impact of the mentioned factor on the usefulness of financial reporting is significant.

Based on the standard factor loading calculated, in external factors, the standard factor loading of media and public networks is equal to 1.05 which is greater than other factors. This suggests the high effect of the above-mentioned factor among the external factors affecting the usefulness of financial reporting in the internal decision-making of governmental organizations. With regard to the collected data, the first research hypothesis stating that “organizational factors (outside the control of management) have a significant impact on the usefulness of financial reporting in the internal decision-making of governmental organizations” is confirmed with 95% confidence.

**6.2.2.2. Testing the second hypothesis**

Individual factors (under the control of management) have a significant influence on the usefulness of financial report information in the internal decision-making of governmental organizations.

Individual factors in this research include the components of the following table. In the Table 6, the factor loading corresponding to them has been presented.

**Table 5: Factor loadings corresponding to the organizational factors (external factors)**

Factor	Standard factor loading	Standard error	T value	Significance level	
Political and governmental structure	0.79	0.96	0.06	13.23	P<0.05
Professional and regulatory organizations	0.71	0.89	0.048	14.84	P<0.05
Media and public networks	0.96	1.05	0.086	9.87	P<0.05
Citizens	0.85	0.88	0.091	10.60	P<0.05

**Table 6: Factor loadings corresponding to the individual factors (internal factors)**

Factor	Standard factor loading	Standard error	T value	Significance level	
Lack of knowledge and proper training in the field of information systems	1.21	0.26	0.10	11.59	P<0.05
Lack of professional experience	1.51	0.19	0.11	13.23	P<0.05
Complexity of information based on the accrual basis of accounting	1.40	-0.40	0.11	13.33	P<0.05
Resistance to change	1.11	0.08	0.092	11.99	P<0.05
Mismatch between accounting information systems and excessive workload	1.26	-0.93	0.088	14.36	P<0.05

Findings of the Table 6 reveals that:

- Factor loading of lack of knowledge and proper training in the field of information systems is equal to 1.21 and its corresponding test statistic is 11.59. Thus, its associated significance level is lower than 0.05 ( $P < 0.05$ ). Hence, it can be stated with 95% confidence that the effect of the mentioned factor on the usefulness of financial reporting is significant.
- Factor loading of lack of professional experience is equal to 1.51 and its corresponding test statistic is 13.23. So, its associated significance level is  $< 0.05$  ( $P < 0.05$ ). Thus, it can be said with 95% confidence that the impact of the mentioned factor on the usefulness of financial reporting is significant.
- Factor loading of information based on the accrual basis of accounting is equal to 1.40 and its corresponding test statistic is 13.33. So, its associated significance level is  $< 0.05$  ( $P < 0.05$ ). Therefore, it can be stated with 95% confidence that the effect of the mentioned factor on the usefulness of financial reporting is significant.
- Factor loading of resistance to change is equal to 1.11 and its corresponding test statistic is 11.99. Therefore, its associated significance level is lower than 0.05 ( $P < 0.05$ ). Thus, it can be said with 95% confidence that the impact of the mentioned factor on the usefulness of financial reporting is significant.
- Factor loading of the mismatch between accounting information systems and excessive workload is equal to 1.26 and its corresponding test statistic is 14.36. Therefore, its associated significance level is lower than 0.05 ( $P < 0.05$ ). Thus, it can be said with 95% confidence that the impact of the mentioned factor on the usefulness of financial reporting is significant.
- Factor loading of the absence of sufficient computational tools for using information is equal to 1.33 and its corresponding test statistic is 12.77. Hence, its associated significance level is lower than 0.05 ( $P < 0.05$ ). Thus, it can be said with 95% confidence that the impact of the mentioned factor on the usefulness of financial reporting is significant.
- Based on the standard factor loading calculated, in internal factors, the standard factor loading of the absence of sufficient

computational tools for using information is equal to 0.97 which is greater than other factors. This indicates the high effect of the above-mentioned factor among the internal factors affecting the usefulness of financial reporting in the internal decision-making of governmental organizations. With respect to the collected data, the second research hypothesis stating that “individual factors (under the control of management) have a significant effect on the usefulness of financial reporting in the internal decision-making of governmental organizations” is confirmed with 95% confidence.

- Finally, according to the findings related to the factor analysis chart approved in this study, the standard factor loading corresponding to external factors is 0.27 and the standard factor loading corresponding to individual (internal) factors is 0.91. This issue, while considering the test statistic corresponding to both factor loadings, suggests that individual factors are more effective in the usefulness of financial reporting in the internal decision-making of governmental organizations based on the opinions of the employees attending the study.

## 7. CONCLUSION

As to the changes in accounting and reporting systems and information usefulness, studies have been generally oriented to the evaluation of the effect of legal and organizational pressures, lack of information on new data prepared according to the accrual basis, lack of human resources and resistance to change. In the meantime, some factors are directly related to the individual characteristics of decision-makers and others as a result of standards and specific organizational conditions. The factors associated with the individual characteristics of decision-makers such as skills, knowledge and experience about the concepts and tools of financial management seem to be especially relevant in determining the rate of the usefulness of financial information (Askim, 2008; Paulsson, 2006; Yamamoto, 2008). The amount of using the data of financial reports depends on the usefulness in data decision which is dependent on the potential benefits of data for



users (relevance, meeting the expectations and so on). But there is one question about the understandability of financial information. Grossi and Reichard (2009) observed that the demand for a set of financial reporting data depends on various individual and organizational factors such as knowledge or culture, universality, use of financial information and the mediating role of suppliers and demandants of effective factors.

What can be stated in the overall conclusion of testing the first research hypothesis indicating the impact of external factors on the intra-organizational decision-making of managers and pressures resulting from the political and governmental structure, professional and regulatory organizations, media and public networks and citizens is that these factors can make a significant positive effect on managerial decisions which in the meanwhile, the role of media and public networks is of great importance in creating transparency of information and resources and expenses particularly in public organizations and providing financial forecasts that will be incorporated in the budget. Considering these indicators is very important in decision-making of governmental organizations. Although the results of the first hypothesis are in line with the results obtained by Nogueira and Jorge (2016), there is significant difference in the amount of the effect of each component on intra-organizational decisions. In earlier research including the study by Nogueira and Jorge (2016), out of the desired factors, the pressure exercised by professional and regulatory organizations has been recognized as the most important driving factor for managerial decisions in governmental organizations. This difference in results can arise from the status of developing the accounting standards of the public sector in different countries and also strengths and weaknesses of the national economy. On the other hand, in the second hypothesis, a significant positive relationship was observed between intra-organizational factors and efficiency of managerial decisions and it was determined that these results are inconsistent with the findings of Nogueira and Jorge (2016). According to previous studies, it was claimed that factors such as pressure from the government, professional organizations and regulatory bodies reduce the impact of intra-organizational factors including knowledge and proper training in the field of information systems on the usefulness of financial information for decision-making and consequently, intra-organizational factors decrease the usefulness of financial reporting for decision-making in response to external pressures.

With regard to the hypothesis results and indicators used in each hypothesis, considering the importance of these indicators in the organization becomes more important than ever before and the organizations involved in this area including State Taxation Affairs Organization and supreme audit court which play an important role in policy-making in this regard should make double effort to improve these indicators. Further, given the results of structural equation modeling test and with regard to investigating the intensity of the effect of these factors on the usefulness in financial information decision-making, it was determined that among the organizational and individual factors, respectively media and public networks and absence of sufficient computational tools have the greatest impact on usefulness in information decision-making.

## 8. RESEARCH LIMITATIONS

Researchers have been always faced with some restrictions in the process of this study, among which inherent limitation of the written questionnaire can be mentioned. On the other hand, since there was no financial support in this study, time limitations of the research were also considered and complexity of human behavior and different reactions are undeniable.

Some auditors have refused to accept the questionnaire. Also, refusal of completing the questionnaire and unanswered questions in the received questionnaires were observed and finally, results of this study only apply to the statistical population intended in this research and in connection with generalizing the results to other statistical populations, caution must be exercised.

## REFERENCES

- Almshah, S.A (2014), Investigating Effective Factors in Adopting Environmental Management Accounting Methods, *Management Accounting*, Seventh Year, No. 23.
- Askim, J. (2008), Determinants of performance information utilization in political decision making. In: Van Doren, W., Van de Walle, S., editors. *Performance Information in the Public Sector: How is it Used?* New York: Palgrave Macmillan.
- Belkaoui, A. (1985), *Accounting Theory*. 2<sup>nd</sup> ed. Lincoln, United Kingdom: Thomson Learning Publishing.
- Carpenter, V., Cheng, B.R., Feroz, E. (2007), Toward an empirical institutional governance theory: Analyses of the decisions by the 50 US state governments to adopt generally accepted accounting principles. *Corporate Ownership and Control*, 4(4), 30-46.
- Carpenter, V., Feroz, E. (2001), Institutional theory an accounting rule choice: An analysis of four US states governments' decisions to adopt generally accepted accounting principles. *Accounting, Organizations and Society*, 26, 565-596.
- Chapman, C., Cooper, D., Miller, P. (2009), *Linking accounting, organizations, and institutions*. Accounting, Organizations and Institutions. Oxford: University Press.
- Chenhall, R. (2003), Management control systems design within its organizational context: Findings from contingency-based research and directions for the future. *Accounting, Organizations and Society*, 28, 127-168.
- Cohen, S., Kaimenakis, N., Zorgios, Y. (2007), Assessing IT as a key success factor for accrual accounting implementation in Greek municipalities. *Financial Accountability and Management*, 23(1), 91-111.
- Grossi, G., Reichard, C. (2009), The Limited use of Financial Data for Governmental Decision-Making – An Exploratory Study with Reference to Germany and Italy. In: 12<sup>th</sup> Biennial Comparative International Governmental Accounting Research (CIGAR) Conference – New Challenges for Public Sector Accounting.
- Haldma, T., Lääts, K. (2002), Contingencies influencing the management accounting practices of Estonian manufacturing companies. *Management Accounting Research*, 13, 379-400.
- Lüder, K. (2002), Research in comparative governmental accounting over the last decade: Achievements and problems. In: Montesinos, V., Vela, J., editors. *Innovations in Governmental Accounting*. Dordrecht: Kluwer Academic Publishers.
- Mack, J. (2004), *An investigation of the Information Requirements of Users of Australian Public Sector Financial Reports* (Unpublished PhD Thesis). Brisbane: Queensland University of Technology.

- Mack, J., Ryan, C. (2006), Reflections on the theoretical underpinnings of the general-purpose financial reports of Australian government departments. *Accounting, Auditing and Accountability Journal*, 1(4), 592-612.
- Momeni, M., Ghiyomi, A (2011), *Statistical analysis Using SPSS*. 1<sup>st</sup> ed. Harlow: New Book Publishing.
- Nogueira, S., Jorge, F. (2016), Explanatory Factors for the use of the Financial Report in Decision-Making: Evidence from Local Government in Portugal, *Spanish Accounting Review*. p11.
- Paulsson, G. (2006), Accrual accounting in the public sector: Experiences from the central government in Sweden. *Financial Accountability and Management*, 22(1), 47-62.
- Presence, M.J., Dorogh, A., Golvost, M. (2015), Investigating the Factors Affecting Failure in the Financial Control System of Executive Agencies, Year 15, No. 59, Summer 94.
- Ryan, C., Trevor, S., Nelson, M. (2002), Accountability disclosures by Queensland local government councils: 1997-1999. *Financial, Accountability and Management*, 18(3), 261-289.
- Safdari, N.M., Memarzadeh, G., Ezzati, M. (2015), Investigating the Role of Organizational Factors on Operational Budgeting Implementation in Implementation of Article 219 of the 5<sup>th</sup> Development Plan Law, *Strategic and Military Policies Quarterly*. Sue Suu, 11, 27-48.
- Taliban, N.G., Abbasi, I., Zarei, B. (2011), The effect of environmental factors on the process of public accounting reform in Iran through the modeling model. *Financial Accounting and Audit Research*, 3(9), 69-96.
- Tarter, C., Hoy, W. (1998), Toward a contingency theory of decision making. *Journal of Educational Administration*, 36, 212-228.
- Thomas, A. (1991), Towards a contingency theory of corporate financial reporting system. *Accounting, Auditing and Accountability Journal*, 4(4), 40-57.
- Tudor, T., Mutiu, A. (2005), Cash versus accrual accounting in public sector. *Studia Oeconomica*, 1, 36-51.
- Vakili-Fard, H., Nazari, F. (2012), Investigating factors affecting the implementation of accrual accounting system in affiliated institutions of the ministry of health and medical education. *Quarterly Journal of Health Accounting*, 1(1), 111-125.
- Yamamoto, K. (2008), What matters in legislators' information use for financial reporting? The case of Japan. In: Jorge, S., editor. *Implementing Reforms in Public Sector Accounting*. Coimbra: Coimbra University Press.